

**General Description**

Series PD and PDC accessory valves are pressure compensated flow dividers. They are designed for applications where two separate hydraulic circuits are to be served from a single pump. The valve splits the flow in three ratios between the two hydraulic lines. Flow through the series PD flow divider cannot be reversed. Flow through the PDC flow divider can be combined in the reverse direction and synchronized in both directions.

Series PD and PDC flow dividers will divide the inlet flow to  $\pm 10\%$  of the specified outlet flow when used within recommended capacities. In addition, many actuators can displace fluid different from the ratio of the divider. This can cause two actuators to either lock up or become out of synch. A means of rephasing the actuators is recommended.

**Operation**

As flow enters the inlet port of the PD version, it will pass through the control orifices in the interconnected spools. The flow passing through the orifices in the spools creates a pressure drop which pulls the two spools away from each other. The flow then passes to the two-divider outlet ports.

When flow is to be combined in the PDC versions, it enters the valve through the two-divider outlet ports. The flow passes through the orifices in the spools creating a pressure drop which pushes the two spools towards each other. The combined flow then passes to the inlet port. The design of the PD spool does not allow flow to combine.

**Features**

- Pressure compensated
- Cross drilled spool provides accurate metering
- High tensile, cast iron body

**Ordering Information**

□	—	□	—	□																								
Flow Divider		Port Size		Ratio																								
<table border="1"> <thead> <tr> <th>Code</th> <th>Description</th> </tr> </thead> <tbody> <tr> <td>PD</td> <td>Flow Divider</td> </tr> <tr> <td>PDC</td> <td>Flow Divider/ Combiner</td> </tr> </tbody> </table>	Code	Description	PD	Flow Divider	PDC	Flow Divider/ Combiner		<table border="1"> <thead> <tr> <th>Code</th> <th>Description</th> </tr> </thead> <tbody> <tr> <td>10</td> <td>SAE-10 (3/4" - 16 UNF)</td> </tr> <tr> <td>12</td> <td>SAE 12 (1 1/16" - 12 UNF)</td> </tr> <tr> <td>50</td> <td>1/2" - 14 NPT</td> </tr> <tr> <td>75</td> <td>3/4" - 14 NPT</td> </tr> </tbody> </table>	Code	Description	10	SAE-10 (3/4" - 16 UNF)	12	SAE 12 (1 1/16" - 12 UNF)	50	1/2" - 14 NPT	75	3/4" - 14 NPT		<table border="1"> <thead> <tr> <th>Code</th> <th>Description</th> </tr> </thead> <tbody> <tr> <td>50</td> <td>50/50</td> </tr> <tr> <td>60</td> <td>60/40</td> </tr> <tr> <td>70</td> <td>70/30</td> </tr> </tbody> </table>	Code	Description	50	50/50	60	60/40	70	70/30
Code	Description																											
PD	Flow Divider																											
PDC	Flow Divider/ Combiner																											
Code	Description																											
10	SAE-10 (3/4" - 16 UNF)																											
12	SAE 12 (1 1/16" - 12 UNF)																											
50	1/2" - 14 NPT																											
75	3/4" - 14 NPT																											
Code	Description																											
50	50/50																											
60	60/40																											
70	70/30																											

NPT pipe ports are not recommended for pressures above 138 Bar (2000 PSI)

**Note: The PDC is only available in a 50/50 ratio.**

**Service Parts**

Spool Seal	3914N-9 (2 required)
------------	----------------------

**Note:** The body and the internal parts are non-service items.

PD-PDC.p65, dd

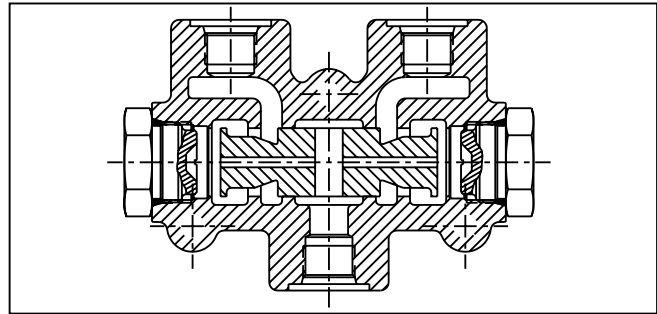
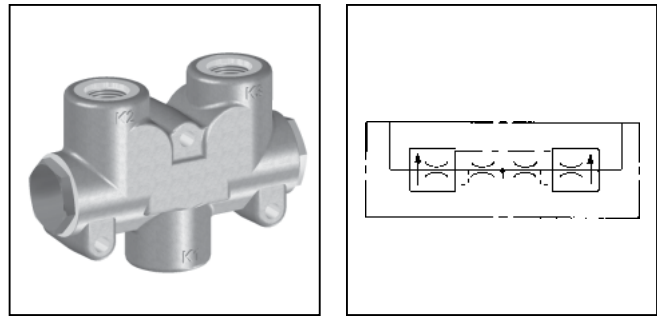

**Specifications**

<b>Input Flow</b> PD / PDC50 PD / PDC75 PD / PDC12	18.75 - 75 LPM (5 - 20 GPM) 75 - 131.25 LPM (20 - 35 GPM) 75 - 131.25 LPM (20 - 35 GPM)
<b>Accuracy</b>	$\pm 10\%$
<b>Operating Pressure</b> SAE Ports NPTF Ports	177 Bar (2500 PSI) 138 Bar (2000 PSI)
<b>Operating Temperature Range (Ambient)</b>	Nitrile Seals: -40°C to +93°C (-40°F to +200°F)
<b>Material</b>	Body – High strength cast iron Spool – Hardened and ground steel
<b>Filtration</b>	ISO Code 16/13 SAE Class 4 or better
<b>Mounting Position</b>	In-line; no restrictions

**Performance Curves**

**In Divider Mode from Inlet to Joined Legs**

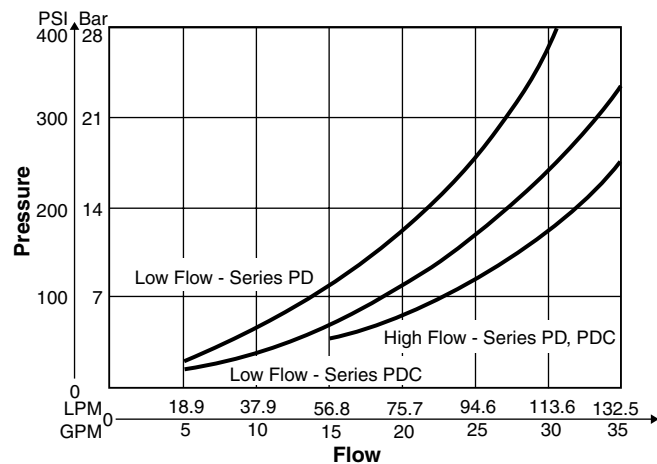

Inch equivalents for millimeter dimensions are shown in (\*\*)

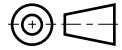

**Series PD**

**Standard Flow Divider**

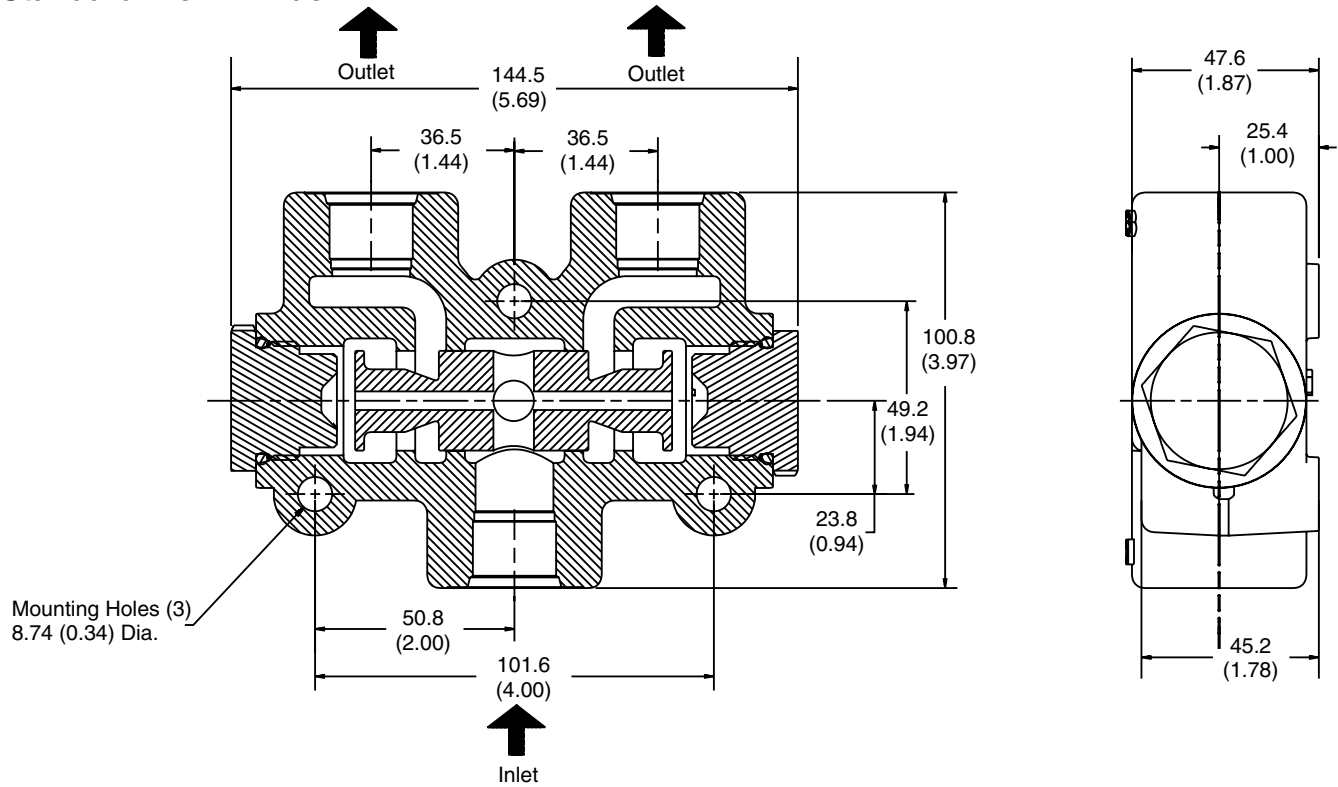

**Series PDC**

**Flow Divider / Combiner**

